

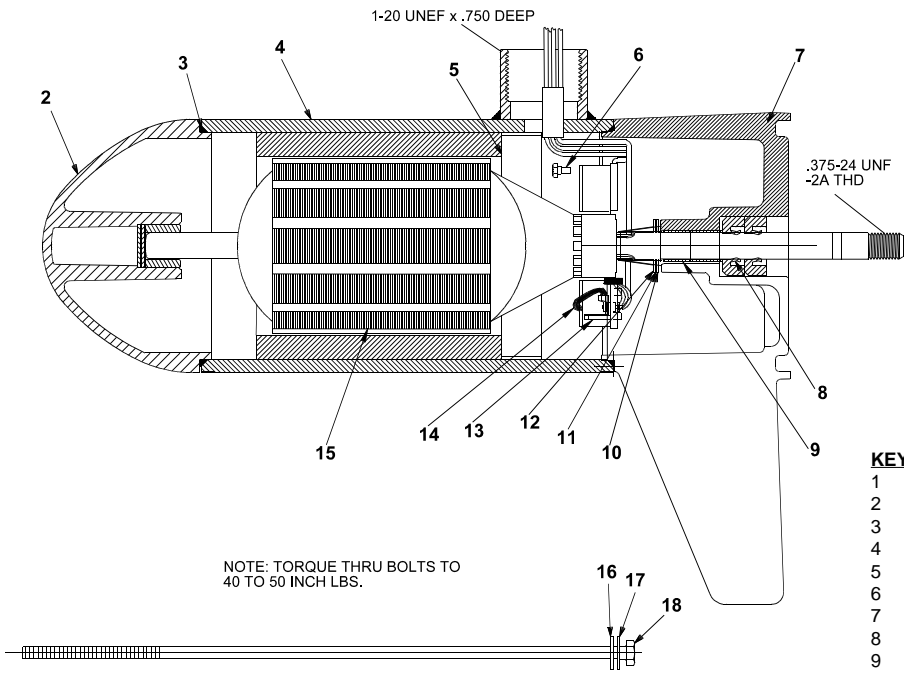

# LOWER UNIT BREAKDOWN

Model:  
**750**  
**Classic**



KEY	QTY	DESCRIPTION	PART NO.
1	X	MOTOR	BF397-03
2	1	NOSE CAP	JF3212-01
3	2	O RING SEAL	MR217-01
4	1	HOUSING ASY	JF3210-01
5	1	RETAINER	JF233-01
6	2	BRUSH CARD SCREW	MR228-01
7	1	COMM CAP	BF3205-02
8	2	SHAFT SEAL	MR223-01
9	1	BEARING	MR206-01
10	1	NYLATRON WASHER	MR226-01
11	1	WASHER	MR227-01
12	1	E RING	MR219-02
13	2	BRUSH SPRINGS	MR214-02
14	1	BRUSH ASY LESS SPRING	BF3201-02
15	1	ARMATURE	JF3207-01
16	4	STATIC SEAL	MR222-01
17	4	THRU BOLT WASHER	MR216-01
18	2	THRU BOLT	MR218-02

## WIRING

12/24 WIRING DIAGRAM

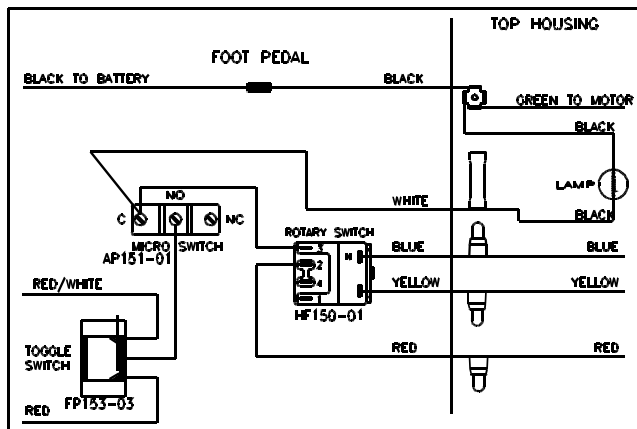

**GEAR ADJUSTMENT**  
Loosely install two bracket mounting screws. Adjust bracket for best tooth engagement. Tighten both mounting screws to 18-20 inch lbs.

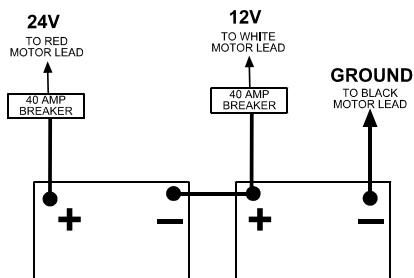
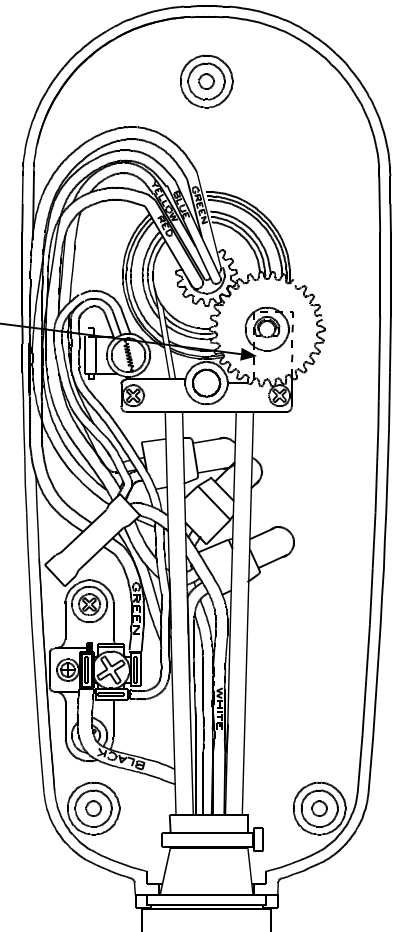

# (BLACK) TOUR EDITION STEP SPEED PEDAL ASSY

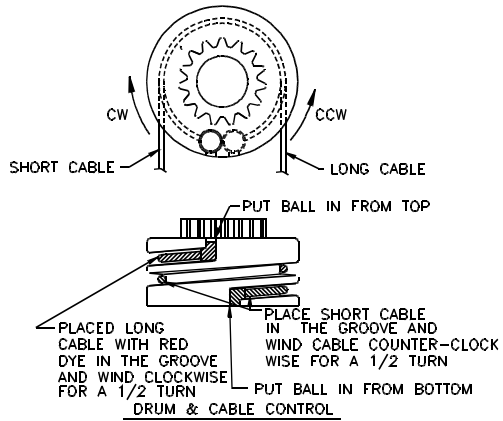

NOTE: APPLY CABLE TO DRUM CONTROL BEFORE PUSHING THE DRUM CONTROL ON THE DRUM COUPLING

ITEM #	DESCRIPTION	PART #
1	SWITCH BOOT	FP177-01
2	TOGGLE SWITCH	PM3153-01
3	SCREW #6X32X1.12	PM135-01
4	6-32 NUT SS	SP098-02
5	MICRO SWITCH	AP151-01
6	FOOT PEDAL	PM101-03
7	ROTARY KNOB	PM082-02
8	NUT PUSH ON	PM046-01
9	ROTARY SWITCH	HF150-01
10	BATTERY CABLE	PM328-03
11	STEERING CABLE SHORT FOR 60"	PM027-01
12	STEERING CABLE LONG FOR 60"	PM027-02
	STEERING CABLE SHORT FOR 72"	PM027-03
	STEERING CABLE LONG FOR 72"	PM027-04
13	DECAL	PM057-04
14	BASE, PEDAL	PM003-01
15	COVER, SWITCH	PM026-01
16	MICRO SWITCH BOOT	KP157-01
17	FOOT PEDAL	PM101-03
18	PAD, FOOT PLATE	PM054-01
19	SCREW	FM133-04
20	PULLEY	PM121-01
21	PIVOT PULLEY	PM122-01

